

# OIL LEVEL INDICATOR BULLS EYE - BRASS

## Douglass

See more, see better



# OIL LEVEL INDICATOR BULLS EYE – BRASS

## Overview:

Douglass bullseye level indicators made in brass are durable and corrosion-resistant components designed for visually monitoring fluid levels and conditions in various industrial applications. Featuring a circular glass window, these indicators allow for easy observation of oil levels and detection of any contamination.

The brass construction ensures long-lasting performance, even in harsh environments, while the threaded design facilitates easy installation into tanks, reservoirs, or pipelines.

These indicators are also straightforward to maintain, ensuring accurate and consistent readings over time. By preventing equipment damage due to low or contaminated oil levels, Douglass bullseye level indicators enhance safety and reliability.

They offer a cost-effective solution for monitoring fluids in hydraulic systems, gearboxes, compressors, and other machinery, thereby ensuring optimal performance and extending the lifespan of essential equipment.

## Application:

- **Hydraulic Systems:** Monitoring the hydraulic fluid level to ensure proper system operation and prevent damage.
- **Gearboxes:** Keeping an eye on oil levels and condition to maintain optimal performance and extend the life of gear components.
- **Compressors:** Ensuring the appropriate oil level in compressors to avoid overheating and mechanical failures.
- **Machinery:** General fluid level monitoring in various types of industrial machinery to ensure smooth and efficient operation.

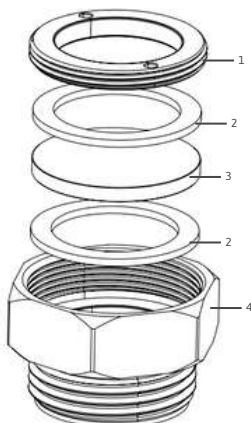

### Parts and available materials:

Item	Part name	Material options
1	Ring	· Brass
2	Gasket	· Buna · EPDM · Neoprene · Viton · Teflon
3	Sight Glass	· Tempered Borosilicate
4	Connection	· Brass



## Types of Indication:

- **Type P (Full View):** Provides a complete view into the tank, allowing for easy observation of the fluid level without any obstructions.
- **Type N (Level Contrast):** Features a bottom painted in white with a red dot in the middle, creating a contrast that makes it easier to indicate the oil level accurately.

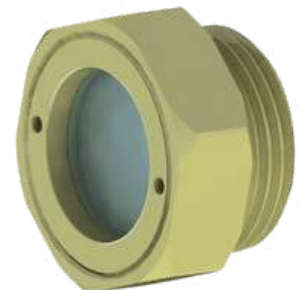

# OIL LEVEL INDICATOR BULLS EYE – BRASS

Satisfaction Guarantee

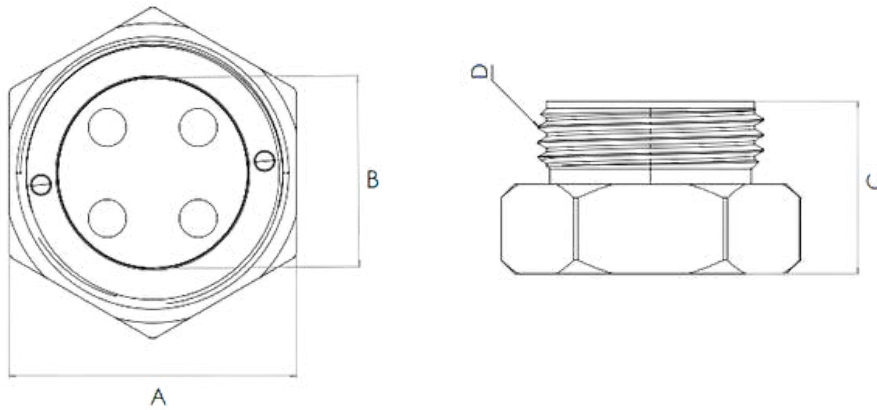

## TECHNICAL INFORMATION

Units	A	B	C	D
1/2"	25mm	23mm	14mm	1/2" NPT / NPS
3/4"	32mm	23mm	19mm	3/4" NPT / NPS
1"	38mm	24mm	25mm	1" NPT / NPS

### Installation of the Oil Level Indicator Bulls Eye

#### Preparation:

Ensure the machine or tank is turned off and depressurized.  
Clean the mounting area on the tank or reservoir to remove any dirt, oil, or debris using a cleaning cloth.

#### Inspect the Sight Glass:

Check the Douglass bullseye sight glass for any visible damage. Verify that the threads and sealing surfaces are clean and intact.

#### Align the Sight Glass:

Position the Douglass bullseye sight glass at the designated mounting point on the tank or reservoir. Ensure the sight glass is oriented for optimal visibility.

#### Thread the Sight Glass:

Carefully thread the sight glass into the mounting port. Hand-tighten initially to ensure the threads are correctly aligned and not cross-threaded.

#### Tighten the Connections:

Use a wrench or spanner to tighten the connections securely. Be cautious not to overtighten, as this can damage the threads or the sight glass.

#### Check Alignment:

Ensure the bullseye sight glass is properly aligned and visible. Adjust if necessary before final tightening.

#### Inspect Seals:

Check all seals and connections to ensure there are no gaps or potential leak points.

#### Test the Installation:

Slowly fill the tank or reservoir with oil while observing the sight glass for any signs of leaks.  
Check the oil level to ensure the sight glass accurately reflects the fluid level.

#### Final Check:

Once the tank is filled, recheck all connections and the sight glass for proper installation and operation.

#### Documentation:

Record the installation date and any observations in the maintenance log for future reference.