

FLANGED 360°
FULL-VIEW
SIGHT FLOW INDICATOR

Douglass

See more, see better



SIGHT FLOW INDICATOR

360° FULL-VIEW FLANGED CONNECTION

Overview:

Sight Flow Indicators are devices used in piping systems to provide a visual indication of the flow of liquids, gases, or slurries within the system. They are crucial for monitoring and verifying the flow and condition of the media without disrupting the process.

Application:

These sight flow indicators, due to its smooth bore ID, prevent product retention regardless of sight flow orientation. Their connection can be adapted to any type or size of flange, and length customized to meet the required face-to-face dimension.

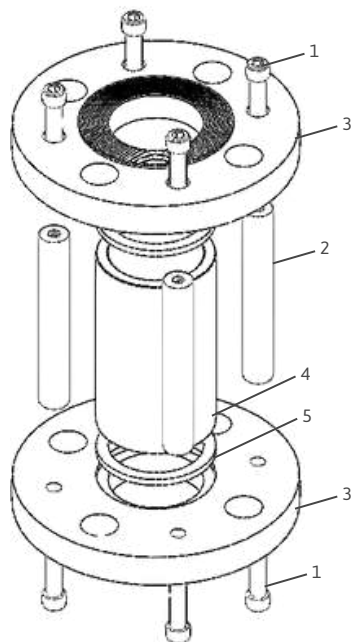

Parts and Materials:

Item	Part name	Material options
1	Allen Bolts	<ul style="list-style-type: none"> Stainless Steel 316L HSS
2	Protection Rods	<ul style="list-style-type: none"> Stainless Steel 316L Stainless Steel 304
3	Flanges	<ul style="list-style-type: none"> Stainless Steel 316L Stainless Steel 304 PTFE PVC
4	Sight Glass	<ul style="list-style-type: none"> Tempered Borosilicate Polycarbonate
5	Gasket	<ul style="list-style-type: none"> Buna Neoprene Teflon Sanitary Rubber EPDM Viton

Benefits:

- **Flange-Flexibility:** This model can be adjusted to any flange specification in any material, giving the user great flexibility by adapting to existing hardware.
- **Face-To-Face Flexibility:** Can be made from 3" up to 48" with stainless steel rods up to 5/8" in diameter to protect extra-long glass cylinders.
- **Glass Compression:** The length of the protecting rods is exactly calculated so it seals the sight glass without applying compression directly to it. This ensures the tempered glass can truly sustain impacts and changes in pressure without cracking.

Key Features:

- Connection type:
 - Flanged
- Flow indication type:
 - Full View 360° Vision
- Working pressure:
 - From 0 to 300 PSI
- Working temperature:
 - From -45°C to 560°C
- Minimum length:
 - 75mm
- Maximum length:
 - 1500mm
- Smallest flange:
 - 1/2"
- Largest flange:
 - 10"

SIGHT FLOW INDICATOR 360° FULL-VIEW FLANGED CONNECTION

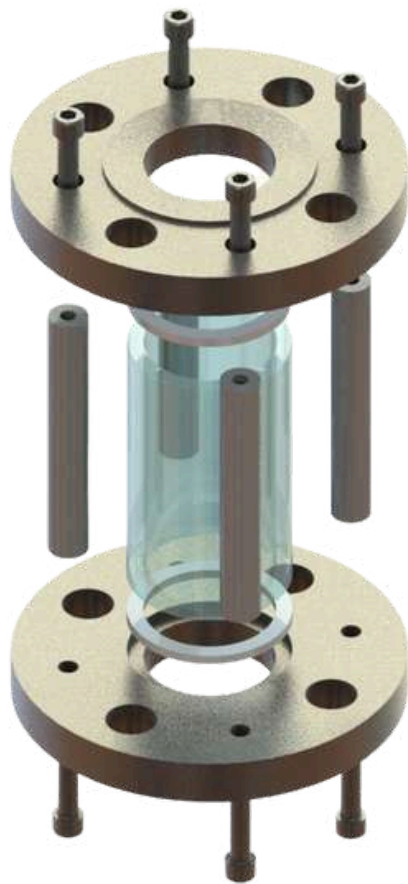

Installation of the Sight Flow Indicator 360° Full - View

Prepare the Installation Area

- Clean the piping system where the sight flow indicator will be installed.
- Check for any debris, rust, or residues that might affect the installation.

Verify all the parts of the assembly

- Inspect the sight flow indicator for any damages or defects.
- Ensure it matches the specifications required for your system (e.g., size, material).

Install Flange Gaskets

- Place gaskets for the flanges on the ends of the sight flow indicator.
- Apply a thin layer of lubricant if recommended by the manufacturer.

Position the Sight Flow Indicator

- Align the sight flow indicator with the piping system.

Secure the Sight Flow Indicator

- Tighten in place the flanges of the sight flow indicator to the pipe flanges
- Tighten the bolts or clamps evenly to ensure a good seal and to avoid oversteering the glass or body of the sight flow indicator.

Check for Alignment

- Verify that the sight flow indicator is properly aligned with the piping system.
- Ensure there is no strain on the sight flow indicator from the piping.

Perform a Leak Test

- Slowly pressurize the system and check for leaks around the sight flow indicator.
- Tighten connections if necessary.

Final Inspection

- Ensure all connections are secure.
- Verify that the sight flow indicator is functioning correctly and that the flow is visible through the indicator.

DON'TS

- DON'T overtighten the bolts as this can stress and crack the sight glass or body.
- DON'T use abrasive cleaning agents or tools that could scratch or damage the sight glass.
- DON'T use with Incompatible Fluids.
- DON'T ignore leaks; address them immediately to prevent system contamination or damage.
- DON'T subject the sight flow indicator to pressures beyond its rated capacity.
- DON'T use any installation methods or operational practices that are not recommended by the manufacturer.
- DON'T expose the sight flow indicator to rapid temperature changes, which can cause thermal shock and damage the glass.
- DON'T neglect regular maintenance, as this is crucial for the longevity and reliability of the sight flow indicator.

DO'S

- DO periodically inspect the sight flow indicator for any signs of wear, damage, or leaks.
- DO keep the sight flow indicator clean to ensure visibility and proper operation. Use appropriate cleaning agents that are compatible with the materials of the indicator.
- DO immediately replace any damaged or worn components to maintain the integrity of the system.
- DO use adequate supports and clamps to secure the sight flow indicator and prevent vibration or movement.

Maintenance

- Regularly check ZIGHT glass for clouding, scratching, erosion, or corrosion. Inspect daily to establish a routine replacement schedule.

Cleaning

- Use non-abrasive cleaners for ZIGHT glass. If needed, use diluted hydrochloric acid, but avoid wire brushes or abrasive materials.

Inspection

- Examine the glass for scratches, corrosion, chips, cracks, or flaws with bright, angled light. Replace glass that is cloudy, roughened, or doesn't clean well.

Storing

- Keep ZIGHT gauge glass in its original packaging until ready to install.

Satisfaction Guarantee

