

WELD TO TANK  
SIGHT GLASS ZW30  
OVAL DESIGN

**Douglass**

See more, see better



# WELD TO TANK

## SIGHT GLASS ZW30 – OVAL DESIGN

### Overview:

The weldable oval sight glasses are devices installed in tanks and pressure vessels to allow the visualization of the contents and the processes occurring inside the tank. The oval shape of the sight glass provides a wide viewing area allowing operators to more easily inspect the tank's contents and internal processes.

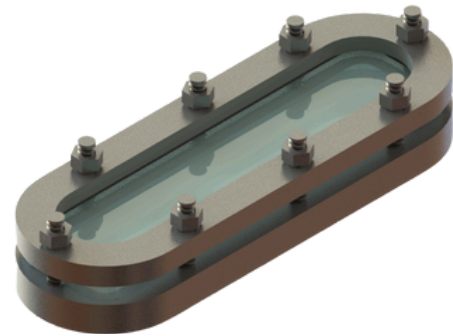

### Advantages:

- **Ease of Installation:** The ZW30 is designed for quick and simple installation, minimizing downtime and labor costs during setup. Its intuitive design ensures even complex installations can be completed efficiently.
- **Aesthetic Design:** The screws are placed on the upper flange, giving the ZW30 a sleek and professional appearance. This makes it an ideal choice for installations where visual appeal is important.
- **Customizable Options:** While the ZW30 comes in standard sizes, it can be customized to meet specific project needs, including adjustments in metal thickness, glass type, and gasket materials.
- **Cost-Effective Solution:** The ZW30 offers a reliable and durable sight glass at a competitive price, making it a great option for industries aiming to balance performance and cost-efficiency.
- **Durable Construction:** Constructed from high-quality materials like carbon steel or stainless steel, the ZW30 is resistant to corrosion and wear, ensuring long-lasting performance even in challenging environments.
- **Versatility:** Suitable for a broad range of industrial applications, from chemical processing to food and beverage production, the ZW30 can adapt to various operating conditions and requirements.
- **Optional LED Lighting:** For installations in low-light environments, the ZW30 can be equipped with an optional LED light, enhancing visibility and safety. The light is protected by a polycarbonate layer to prevent damage from potential explosions inside the tank.

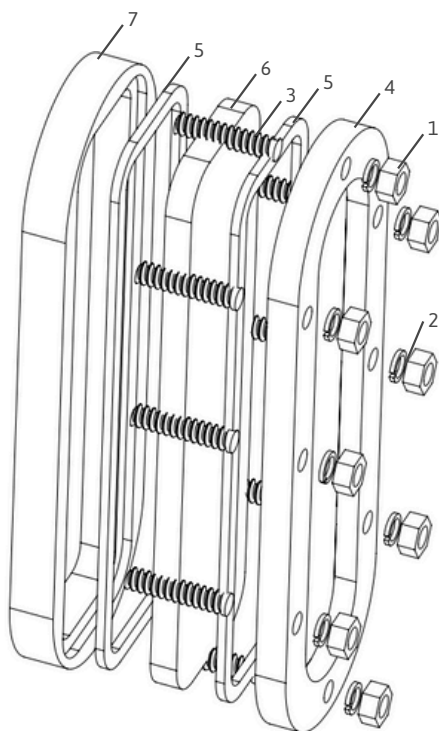

### Parts and Materials:

Item	Part name	Material options
1	Nut	<ul style="list-style-type: none"> <li>· Stainless Steel 316L</li> <li>· Stainless Steel 304</li> </ul>
2	Washer	<ul style="list-style-type: none"> <li>· Stainless Steel 316L</li> <li>· Stainless Steel 304</li> </ul>
3	Stud bolt	<ul style="list-style-type: none"> <li>· Stainless Steel 316L</li> <li>· Stainless Steel 304</li> </ul>
4	Cover Flange	<ul style="list-style-type: none"> <li>· Stainless Steel 316L</li> <li>· Stainless Steel 304</li> <li>· Carbon Steel w/ anti-corrosion coating</li> </ul>
5	Gasket	<ul style="list-style-type: none"> <li>· Buna</li> <li>· Neoprene</li> <li>· Teflon</li> <li>· Sanitary Rubber</li> <li>· EPDM</li> <li>· Viton</li> </ul>
6	Sight Glass	<ul style="list-style-type: none"> <li>· DIN7080 Tempered Borosilicate</li> <li>· DIN8902 Tempered Soda Lime</li> <li>· Polycarbonate</li> <li>· Quartz</li> </ul>
7	Weld Pad	<ul style="list-style-type: none"> <li>· Stainless Steel 316L</li> <li>· Stainless Steel 304</li> <li>· Carbon Steel w/ anti-corrosion coating</li> </ul>

# WELD TO TANK

## SIGHT GLASS ZW30 - OVAL DESIGN

TECHNICAL INFORMATION			
300 PSI			
PART ID	Visible dimensions (internal) A x B	Weldable dimensions (external) C x D	Flange thickness H1 x H2
ZW30-CO-200X20	200 x 20	270 x 70	15 x 25
ZW30-CO-270X20	270 x 20	340 x 70	15 x 25
ZW30-CO-340X20	340 x 20	410 x 70	15 x 25
ZW30-CO-410X20	410 x 20	480 x 70	15 x 25
ZW30-CO-480X20	480 x 20	550 x 70	15 x 25
ZW30-CO-550X20	550 x 20	620 x 70	15 x 25
ZW30-CO-620X20	620 x 20	690 x 70	15 x 25
ZW30-CO-690X20	690 x 20	760 x 70	15 x 25

### Installation Instructions for Oval Sight Glass (Douglass Brand):

#### Tools and Materials Required:

- Welding machine
- Welding rods/electrodes (appropriate for materials)
- Torque wrench (calibrated)
- Gaskets (as specified, typically non-reusable)
- Bolts and nuts (as specified)
- Protective gear (welding mask, gloves, etc.)
- Optional: LED light kit

#### 1. Preparation:

- Clean the tank surface and ensure the opening is clear of any debris or rust.
- Ensure all necessary components (oval sight glass, gaskets, bolts, nuts, etc.) are available and in good condition.

#### 2. Position the Oval Sight Glass:

- Place the Douglass Oval Sight Glass onto the tank's opening.
- Align the longer and shorter axes of the oval properly with the tank opening to ensure a proper fit.
- Mark the locations for welding if required.

#### 3. Welding:

- Weld the oval sight glass neck or flange to the tank using an appropriate welding technique (TIG/MIG), ensuring the weld follows the curves of the oval shape uniformly.
- Pay special attention to the narrow ends of the oval to avoid uneven stress.
- Ensure a continuous, full-penetration weld to create a secure, leak-proof seal.
- Allow the welded area to cool naturally to avoid stress or warping.

#### 4. Install Glass and Gaskets:

- Place the first gasket onto the flange of the oval sight glass, ensuring proper alignment along the entire oval shape.
- Carefully center the oval glass onto the gasket.
- Add a second gasket on top of the glass if required by the design.

#### 5. Secure the Assembly:

- Align the upper flange with the oval neck/flange.
- Insert bolts into the designated holes, ensuring they are evenly spaced around the oval.
- Tighten the bolts gradually in a criss-cross (star) pattern to ensure even compression of the gasket around the entire oval.
- Use a torque wrench to tighten the bolts to the specified torque values, avoiding over-tightening, especially around the narrower ends of the oval.

#### 6. Final Checks:

- Inspect the welding for any gaps, cracks, or defects.
- Ensure the gasket is evenly compressed along the entire oval shape and that the sight glass is securely aligned with no signs of stress or damage.

#### 7. Optional: Install LED Light:

- Install the optional LED light kit according to the manufacturer's instructions.
- Ensure the light is properly connected and functional.

#### 8. Testing:

- Perform a pressure test to verify that there are no leaks and the oval sight glass is securely installed.
- Inspect for any potential misalignments or weak points, especially around the narrower ends of the oval.

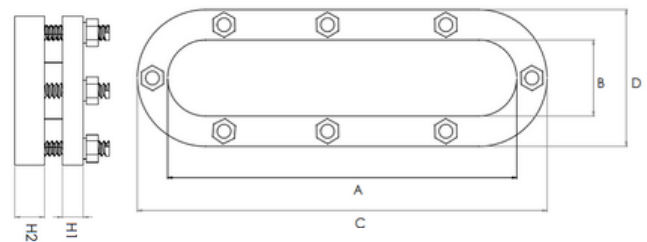

#### Do's:

1. Do inspect regularly: Conduct routine inspections to ensure the sight glass, gaskets, and welds are in good condition.
2. Do replace gaskets as needed: Always use new, undamaged gaskets when performing maintenance or if leaks are detected.
3. Do clean the glass: Keep the sight glass clean both inside and outside to maintain clear visibility.
4. Do follow torque specifications: Use a torque wrench to evenly tighten bolts to the specified torque value during installation and maintenance.
5. Do depressurize the tank: Always depressurize the tank before performing any maintenance or replacement on the sight glass.

#### Don'ts:

1. Don't reuse gaskets: Never reuse old gaskets; this can lead to leaks or improper sealing.
2. Don't overtighten bolts: Over-tightening can damage the glass or gaskets, leading to potential leaks or failure.
3. Don't ignore signs of damage: If you notice any cracks, chips, or other damage to the glass, replace it immediately to avoid safety hazards.
4. Don't use abrasive cleaners: Avoid using abrasive materials or harsh chemicals to clean the glass, as they can scratch or weaken it.
5. Don't skip regular maintenance: Failing to maintain the sight glass can lead to decreased performance, leaks, and potential safety issues.

#### How to order:

To make the ordering and specification of your Oval ZW30 easier, please ask your sales representative for a model by filling out the following chart: Keep in mind these are for standard items, any custom-made application can be tackled directly with your sales representative.

ZW30-CO -	-	-	-	-	-
	↑	↑	↑	↑	
	Visible Diameter	Flange Material:	Gasket Material:	Sight Glass Material:	
		• S6: SS316	• EG: Expanded Graphite	• TB: Tempered Borosilicate	
		• S4: SS304	• NA: Non Asbestos	• QZ: Quartz	
		• CS: Carbon Steel	• PT: PTFE	• SL: Tempered Soda Lime	
			• GK: Graphite/Kevlar		