

LEVEL GAUGE VALVES  
BRASS 250 PSI  
ZTV-25BR

**Douglass**

See more, see better



**Douglass**

See more, see better

# LEVEL GAUGE VALVES BRASS 250 PSI ZTV-25BR

## Why should I choose Douglass Tubular Level Gauge Valves:

Douglass valves are the perfect choice for customers seeking durable, high-quality valves. With superior design and precise manufacturing, our valves are crafted to meet the highest industry standards. We offer a single type of valve that is versatile and suitable for a wide range of applications.

## What makes Douglass different from other brands?

By having a single model that suits a wide range of applications, we were able to develop the most competitive valve on the market. We offer a high-quality product at a highly competitive price so customers don't have to cover indirect costs such as transportation, storage and tariffs typically associated with purchasing imported products.

As a result, our ZTV-25BR valves are well positioned with great acceptance throughout the North and South American markets.

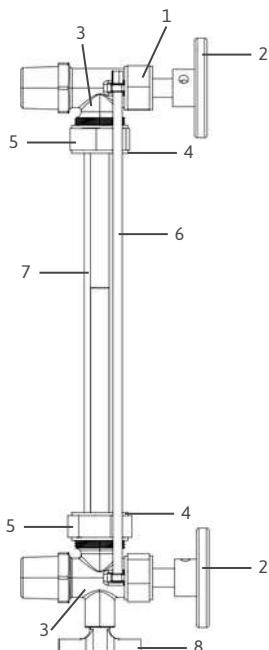

### Parts and available materials:

Item	Part name	Material options
1	Stopper	Brass
2	Handle	Aluminum
3	Body (Upper & Lower)	Brass
4	Tubular Gasket	EPDM / Zyton
5	Tightening Nut	Brass
6	Protection Rods	Aluminum
7	Glass Tube	Borosilicate Polycarbonate
8	Drain	Brass

### Features:

- Connection type: NPT threaded.
- Flow indication type: Transparent / Red line.
- Working Pressure: From 0 to 250 PSI.
- Working temperature: From -45°C to 270°C
- Gaskets included: EPDM / Zyton
- Handle: Aluminum
- Drain: Sampler lower vent
- Safety check: SS316 Safety Ball Check

**Douglass**

See more, see better

# LEVEL GAUGE VALVES BRASS 250 PSI ZTV-25BR

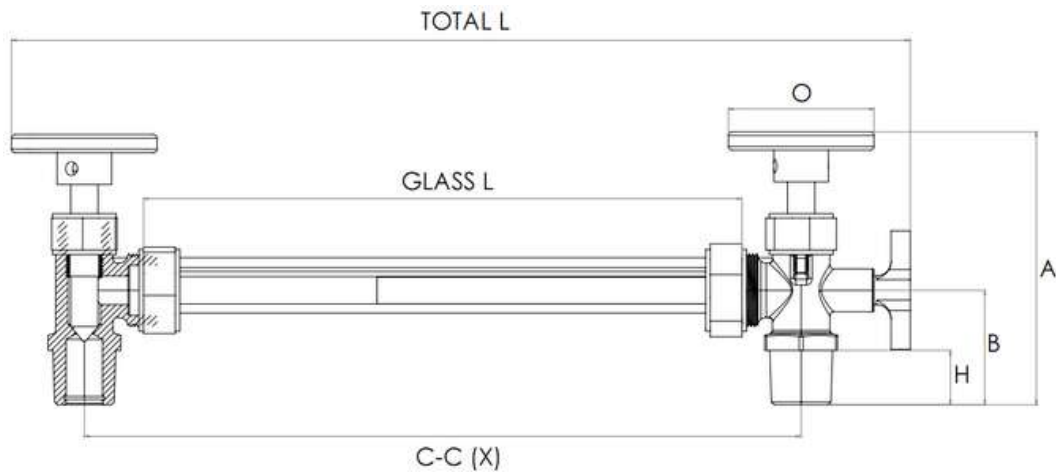

## TECHNICAL INFORMATION

	GLASS L	ROD L	TOTAL L	A	B	H	O	DRAIN
1/2"	X - 2"	X + 1"	X + 2-5/8"	MAX 4"	1-1/2"	3/4"	2"	3/8"-24
3/4"	X - 2-1/4"	X + 1"	X + 2-7/8"	MAX 4-1/8"	1-5/8"	3/4"	2"	3/8"-24

### How to estimate length of glass tube:

Tube length = Center-to-Center - 2"

### How to estimate length of protective rods:

Rod length = Center-to-Center + 1"

### How to estimate total length of level equipment:

Total length = Center-to-Center + 2-5/8"



**Douglass**

See more, see better

# LEVEL GAUGE VALVES BRASS 250 PSI ZTV-25BR

Satisfaction Guarantee



## Installation of the Level Gauge Valves

### Preparation:

- Inspect all components for damage.
- Ensure all parts are clean and free of debris.

### Installing the Top Fitting:

- Apply Teflon tape to pipe threads.
- Install the top gauge fitting into the uppermost tapping, ensuring the glass outlet is at a 5 o'clock position (about 1/8 turn from its final, downward vertical position).

### Installing the Bottom Fitting:

- Install the bottom gauge fitting with a drain valve into the lower tapping, ensuring it is pointing directly upward. Make sure the top and bottom fittings are threaded into the tappings the same number of turns.

### Removing and Placing Packing Components:

- Remove the glass packing nut, friction washer (or packing gland and retaining ring), and glass packing from both fittings.
- Place these components back onto the ends of the gauge glass, pushing the packings about an inch up the gauge glass.

### Inserting the Glass:

- Gently insert one end of the glass into the top fitting. Rotate the top fitting clockwise until vertically aligned with the bottom fitting, then insert the glass into the bottom fitting until it bottoms out on the shoulder inside the bottom fitting.

### Positioning the Glass:

- Raise the glass about 1/16" and slide the lower glass packing down until it contacts the lower fitting. Ensure the glass does not contact any metal.

### Securing the Packing:

- Slide the upper glass packing up as far as possible.
- Hand tighten both packing nuts, then tighten an additional 1/2 turn with a wrench. Tighten only enough to prevent leakage without over-tightening. Adjust slightly if any leakage occurs, checking for leakage after each turn.

## DON'TS

- DON'T use ZIGHT glass tubes if they have scratches, chips, or visible damage.
- DON'T reuse any ZIGHT tubular glass or glass packings.
- DON'T expose gauge glass to bending or torsional stress.
- DON'T over-tighten glass packing nuts.
- DON'T let glass touch any metal parts.
- DON'T exceed the recommended pressure for the gauge or glass.
- DON'T clean the gauge or glass while it's pressurized or in operation.

## DO'S

- DO ensure you have the correct Douglass valves.
- DO carefully inspect ZIGHT glass tubes and packings for damage before installation.
- DO install protective guards and use automatic ball checks to prevent injury from glass breakage.
- DO inspect the gauge glass daily, keep maintenance records, and perform routine replacements.
- DO protect the glass from sudden temperature changes, such as drafts or water spray.

## Maintenance

- Regularly check ZIGHT glass for clouding, scratching, erosion, or corrosion. Inspect daily to establish a routine replacement schedule.

## Cleaning

- Use non-abrasive cleaners for ZIGHT glass. If needed, use diluted hydrochloric acid, but avoid wire brushes or abrasive materials.

## Inspection

- Examine the glass for scratches, corrosion, chips, cracks, or flaws with bright, angled light. Replace glass that is cloudy, roughened, or doesn't clean well.

## Storing

- Keep ZIGHT gauge glass in its original packaging until ready to install.

**Douglass**

See more, see better

# TRI COCKS - BRASS

## Why should I choose Douglass Tubular Level Gauge Valves:

Douglass valves are the perfect choice for customers seeking durable, high-quality valves. With superior design and precise manufacturing, our valves are crafted to meet the highest industry standards. We offer a single type of valve that is versatile and suitable for a wide range of applications.

## What is a Douglass tricock valve?

Douglass tricock valves are essential components used in steam boilers from various manufacturers, functioning as manual water level indicators. Strategically installed at three distinct heights on the water column (low, middle, and high), these valves enable operators to accurately assess the water level within the boiler. By sequentially opening each tricock, the operator can observe whether water or steam is released, providing a clear indication of the internal water level. This straightforward yet effective method ensures a reliable check of the boiler's water level, maintaining it within safe operational limits. As a vital backup to automatic water level controls, Douglass tricocks offer an additional safety measure, mitigating the risks associated with low water conditions, such as overheating or potential boiler failure.

## Installation:

Proper installation of Douglass tricock valves is critical for ensuring accurate water level readings and optimal safety in steam boilers. Begin by selecting appropriate installation points at low, middle, and high positions on the boiler's water column. Securely mount each tricock valve to ensure a tight seal, preventing any leaks. Ensure the valves are aligned correctly and free from obstructions to allow clear visibility of water or steam discharge. Finally, test each tricock for proper operation and verify that all connections are secure. Proper installation guarantees reliable manual water level monitoring and enhances the overall safety and efficiency of the steam boiler system.

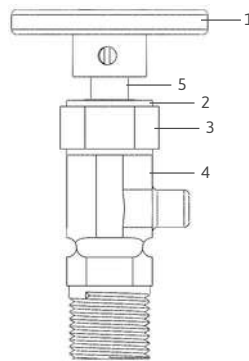

## Parts and available materials:

Item	Part name	Material options
1	Handle	Aluminum
2	Tubular Gasket	EPDM / Zytan
3	Tightening Nut	Brass
4	Body	Brass
5	Stem	Brass

## Maintenance:

Proper maintenance of Douglass tricock valves is crucial for reliable performance in steam boilers. Regularly inspect for wear, corrosion, and damage, replacing any compromised parts. Operate each valve periodically to ensure smooth operation and clean the openings to prevent blockages. Lubricate moving parts as needed and perform routine pressure tests to confirm durability. Consistent maintenance ensures accurate water level monitoring and safe boiler operation.