

THREADED DOUBLE WINDOW
SIGHT FLOW INDICATOR
BRASS - 150 PSI

Douglass

See more, see better



SIGHT FLOW INDICATORS

THREADED DOUBLE WINDOW BRASS

Overview:

Sight Flow Indicators are devices used in piping systems to provide a visual indication of the flow of liquids, gases, or slurries within the system. They are crucial for monitoring and verifying the flow and condition of the media without disrupting the process.

These brass double window sight flow indicators allow for a cost-effective way to monitor your pipe without sacrificing reliability or quality, as they are made from one single forged unit.

Add-ons to improve flow visibility

These sight flow indicators can have additions which help the user have a clearer view of the process,

- **Full View**
 - For easily visible fluids, with color, turbulence, and clarity. They easily detect the presence of solids or foreign products in the handled fluid. They can be mounted in any position.
- **Flapper**
 - Internally mounted with a PTFE Flapper, where the position indicates the direction of the fluid. Used in clear fluids that are difficult to observe, they are normally mounted horizontally, only mounted in a vertical positions with ascending fluids.
- **Drip**
 - Allow for the formation of drops of low-volume or intermittent fluids, for example in unitary distillation operations. They are mounted only in a vertical position and descending flows.
- **Spinner**
 - Internally mounted with a PTFE spinner that rotates with the passage of the fluid, widely facilitating the flow-observation of dark, translucent, and clear fluids that are difficult to observe with the naked eye. They can be mounted interchangeably in any horizontal or vertical position.

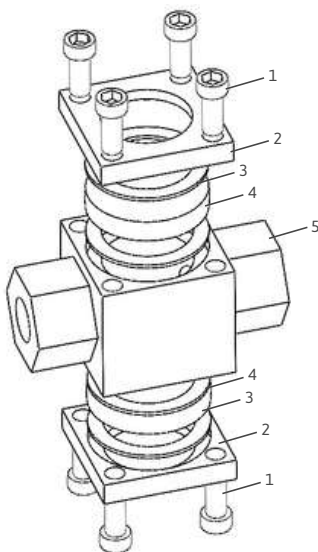
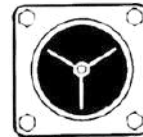
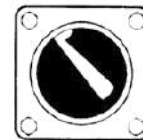
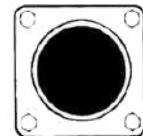

Parts and Materials:

Item	Part name	Material options
1	Allen Bolts	· Stainless Steel 304
2	Cover	· Brass
3	Gasket	· Buna · Sanitary Rubber · Neoprene · EPDM · Teflon · Viton
4	Sight Glass (max temp)	· Tempered Borosilicate · Soda Lime · Polycarbonate · Quartz
5	Body	· Brass

Satisfaction Guarantee



SIGHT FLOW INDICATORS

THREADED DOUBLE WINDOW BRASS

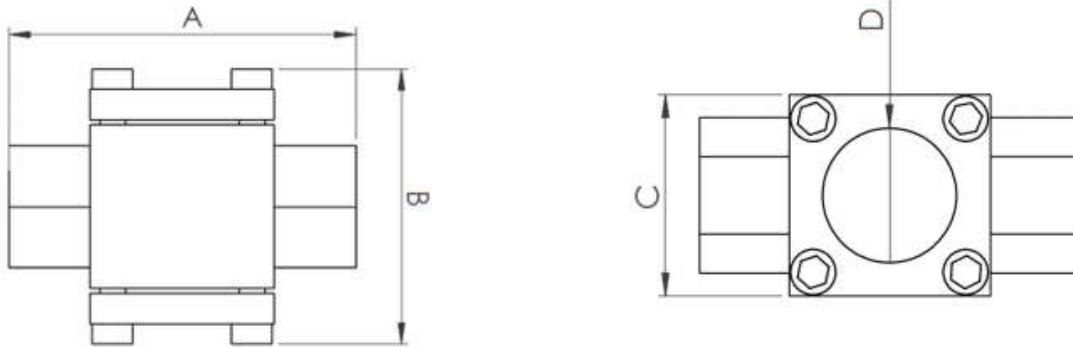

TECHNICAL INFORMATION							
Measure	1/4" NPT	3/8" NPT	1/2" NPT	3/4" NPT	1" NPT	1-1/4" NPT	1-1/2" NPT
A (Dist between faces)	3.25" (82.55mm)	3.25" (82.55mm)	3.25" (82.55mm)	4.25" (107.95mm)	4.25" (107.95mm)	5.25" (133.35mm)	5.25" (133.35mm)
B (Dist between caps)	2.25" (57.15mm)	2.25" (57.15mm)	2.25" (57.15mm)	3.25" (82.55mm)	3.25" (82.55mm)	3.5" (88.9mm)	3.5" (88.9mm)
C (Max Width)	1.75" (44.45mm)	1.75" (44.45mm)	1.75" (44.45mm)	2.25" (57.15mm)	2.25" (57.15mm)	3" (76.2mm)	3" (76.2mm)
D (Visible Diameter)	1" (25.40mm)	1" (25.40mm)	1" (25.40mm)	1.5" (38.10mm)	1.5" (38.10mm)	2" (50.8mm)	2" (50.8mm)

Installation Instructions

1. **Safety First:**
 - o Ensure the system is depressurized and drained.
 - o Wear appropriate PPE, such as gloves, safety glasses, and protective clothing.
2. **Prepare the threads:**
 - o Clean the threads on the pipe ends where the sight flow indicator will be installed. Ensure they are free of debris, rust, or old gasket material.
 - o Inspect the threads for any damage or irregularities. Replace any damaged parts as necessary.
3. **Position the Gaskets:**
 - o Place the gaskets between the flanges of the sight flow indicator and the pipe flanges. Ensure the gaskets are properly aligned with the bolt holes.
4. **Align the Sight Flow Indicator:**
 - o Align the sight flow indicator between the pipe flanges, ensuring that the flow direction marked on the indicator matches the flow direction of the system.
 - o Use pipe alignment tools if necessary to ensure proper alignment.
5. **Tighten the sight flow indicator using :**
 - o In case both pipes have the same female/female or male/male connections, use threaded unions.
 - o Hand-tighten the threads to hold the sight flow indicator in place. Ensure the sight flow indicator remains aligned and that the gaskets are correctly positioned. Then tighten to achieve a positive seal in the NPT threads.
6. **Tighten the Bolts:**
 - o Using a torque wrench, tighten the bolts in a cross-pattern (star pattern) to ensure even compression of the gasket and proper sealing.
 - o Gradually increase the torque in increments, following the manufacturer's recommended torque values for the bolts and flanges. Typically, you would tighten to 30%, 60%, and then 100% of the final torque value.
 - o Re-check the torque on each bolt after the initial tightening sequence to ensure all bolts are evenly tightened.
7. **Final Inspection:**
 - o Inspect the installation to ensure there are no gaps between the flanges and that the sight flow indicator is securely fastened.
 - o Verify that the sight windows are clean and undamaged.
8. **Test the System:**
 - o Gradually pressurize the system and check for leaks around the sight flow indicator flanges.
 - o If any leaks are detected, depressurize the system and re-check the flange bolts for proper torque. Tighten if necessary.
9. **Operational Check:**
 - o Once the system is confirmed to be leak-free, check the operation of the sight flow indicator to ensure that fluid flow can be observed through the windows.
 - o Ensure the sight flow indicator is functioning as intended and that the flow direction is correct.

DO'S

- DO periodically inspect the sight flow indicator for any signs of wear, damage, or leaks.
- DO keep the sight flow indicator clean to ensure visibility and proper operation. Use appropriate cleaning agents that are compatible with the materials of the indicator.
- DO immediately replace any damaged or worn components to maintain the integrity of the system.
- DO use adequate supports and clamps to secure the sight flow indicator and prevent vibration or movement.

DON'TS

- DON'T overtighten the bolts or clamps as this can stress and crack the sight glass or body.
- DON'T use abrasive cleaning agents or tools that could scratch or damage the sight glass.
- DON'T use with Incompatible Fluids.
- DON'T ignore leaks; address them immediately to prevent system contamination or damage.
- DON'T subject the sight flow indicator to pressures beyond its rated capacity.
- DON'T use any installation methods or operational practices that are not recommended by the manufacturer.
- DON'T expose the sight flow indicator to rapid temperature changes, which can cause thermal shock and damage the glass.
- DON'T neglect regular maintenance, as this is crucial for the longevity and reliability of the sight flow indicator.

Maintenance

- Perform regular visual inspections to identify any damage, corrosion, or residue buildup on the glass or frames. Inspections should be more frequent in highly corrosive or high-pressure environments.

Cleaning

- Use non-abrasive cleaners for ZIGHT glass. If needed, use diluted hydrochloric acid, but avoid wire brushes or abrasive materials.

Inspection

- Examine the glass for scratches, corrosion, chips, cracks, or flaws with bright, angled light. Replace glass that is cloudy, roughened, or doesn't clean well.