

FLANGE-TO-TANK SIGHT GLASS WINDOW

Douglass

See more, see better



SIGHT GLASS WINDOW FLANGE-TO-TANK CONNECTION

Overview

Douglass flanged sight windows consist of three parts: the flange on the tank, the bottom flange, and the cover flange.

- The bottom flange, which is not welded, is designed with the same dimensions as a standard flange but adapted to accommodate bolts and glass.
- The cover flange maximizes the viewing area. Installation is simple, as the bottom flange is bolted directly to the tank's flange, creating a "sandwich" assembly, hence the name "sandwich sight glasses."

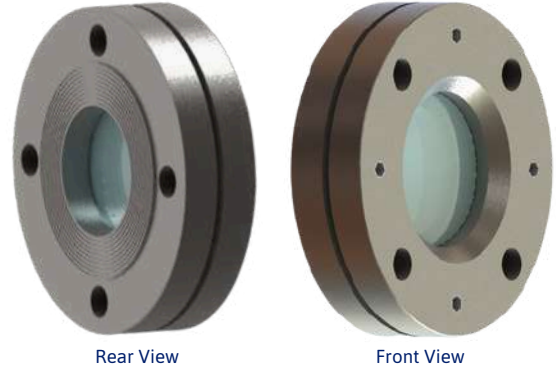

Key Features

- **Non-Welded Assembly for Easy Installation:** This sight glass window eliminates the need for welding, making installation straightforward. The bottom flange bolts directly to the tank's existing flange, creating a secure "sandwich" assembly. This feature greatly simplifies maintenance and replacement, as it avoids the complexities and safety concerns associated with welding on-site, reducing installation time and labor costs.
- **Customization Flexibility in Size and Material:** The sight glass can be manufactured to fit any flange size and is adaptable to a wide range of materials, including stainless steel, carbon steel, or special alloys that match the existing tank flange. This adaptability ensures that the sight glass can be tailored to specific operational needs, including corrosive environments or sanitary applications, making it a versatile solution for various industries.
- **Virtually Unlimited Pressure Resistance:** The pressure resistance of the sight glass assembly is largely dictated by the selected flange and glass specifications. By choosing a higher pressure-rated flange and increasing the glass thickness, the assembly can be configured to withstand extremely high pressures. This modular approach allows the sight glass to be used in demanding applications where pressure limitations would typically pose a constraint, ensuring safety and durability in harsh operating conditions.

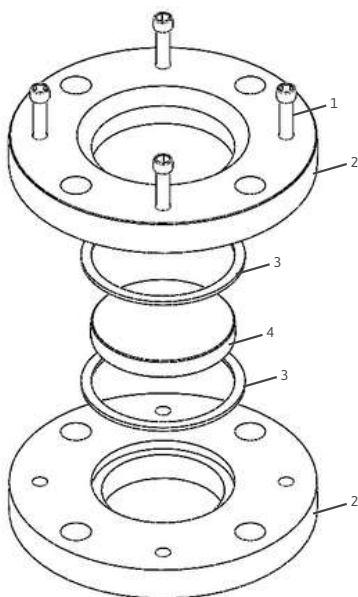

Parts and Materials:

Item	Part name	Material options
1	Allen Bolts	<ul style="list-style-type: none"> • Stainless Steel 316L • Stainless Steel 304
2	Flanges	<ul style="list-style-type: none"> • Stainless Steel 316L • Stainless Steel 304 • Carbon Steel w/ anti-corrosion coating • PTFE • PVC • Acrylic
3	Gasket	<ul style="list-style-type: none"> • Buna • Neoprene • Teflon • Sanitary Rubber • EPDM • Viton
4	Sight Glass	<ul style="list-style-type: none"> • Tempered Borosilicate Sight Glass • Tempered Soda Lime Sight Glass • Polycarbonate • Quartz

Satisfaction



Guarantee

SIGHT GLASSES

FLANGE-TO-TANK CONNECTION

TECHNICAL INFORMATION

ID	A (Visible Diameter)	B (Total Diameter)	C (Minimum Thickness)
3"	3" (76.20 mm)	7.5" (190.50 mm)	2" (50.80 mm)
4"	4" (101.6 mm)	9" (230.00 mm)	2" (50.80 mm)
5"	5" (127.00 mm)	10" (255.00 mm)	2.5" (63.50 mm)
6"	6" (152.40 mm)	11" (280.00 mm)	3" (76.20 mm)
8"	8" (203.20 mm)	13.5" (345.00 mm)	3.5" (88.90 mm)
10"	10" (254.00 mm)	16" (405.00 mm)	3.5" (88.90 mm)
12"	12" (304.80 mm)	19" (485.00 mm)	3.5" (88.90 mm)

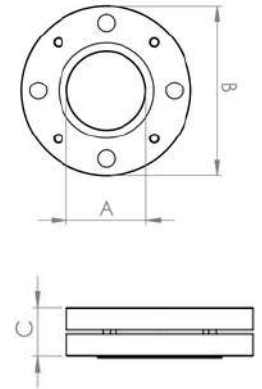

IMPORTANT INFORMATION

Preparation:

1. **Verify Compatibility:** Ensure that the flange size and type on your tank match the specifications of the Douglass Flange-To-Tank Sight Glass.
2. **Check Components:** Inspect the sight glass, gaskets, bolts, and other hardware to confirm they are in good condition and free from any defects or contamination.
3. **Safety Precautions:** Wear appropriate personal protective equipment (PPE) such as gloves, safety glasses, and a face shield. Ensure that the tank is depressurized and emptied before beginning the installation.

Installation Steps:

1. **Clean the Flange Surface:**
 - o Thoroughly clean the flange surface on the tank where the sight glass will be installed. Remove any debris, rust, or old gasket material to ensure a smooth and even surface.
2. **Position the Gasket:**
 - o Place a new gasket on the flange of the tank. Ensure that the gasket is aligned correctly with the bolt holes on the flange. The gasket material should be appropriate for the operating conditions (temperature, pressure, and fluid type).
3. **Mount the Sight Glass:**
 - o Carefully position the Douglass Flange-To-Tank Sight Glass on top of the gasket, aligning the bolt holes with the flange. The sight glass should sit flush against the gasket without any gaps.

Install the Bolts:

- o Insert the bolts through the aligned holes in the flange, gasket, and sight glass. It's recommended to use stainless steel or another corrosion-resistant material for the bolts, depending on the application.
 - o Place washers and nuts on the bolts, tightening them by hand initially to hold the sight glass in place.
1. **Tighten the Bolts:**
 - o Using a torque wrench, gradually tighten the bolts in a criss-cross pattern (or star pattern) to ensure even pressure distribution across the flange. This helps prevent gasket deformation and ensures a proper seal.
 - o Refer to the manufacturer's torque specifications for the bolts, which can vary depending on the size of the flange and the material of the gasket.
 2. **Final Inspection:**
 - o After tightening, inspect the sight glass installation to ensure that the gasket is evenly compressed and that there are no visible gaps or misalignments.
 - o Confirm that the sight glass is secure and properly seated on the flange.

Post-Installation:

1. **Pressure Test:**
 - o Gradually pressurize the tank to the operating pressure and inspect the sight glass installation for any leaks or signs of failure. Monitor for a few minutes to ensure the seal is holding properly.
 - o If a leak is detected, depressurize the tank immediately and retighten the bolts or replace the gasket if necessary.
2. **Operational Check:**
 - o Once the pressure test is successful, the tank can be returned to normal operation. Monitor the sight glass during the first few hours of operation to ensure it is functioning correctly and maintaining a proper seal.
3. **Maintenance Tips:**
 - o Periodically inspect the sight glass during routine maintenance to ensure the gasket remains in good condition and the bolts are secure. Replace the gasket at the first sign of wear or damage.

Do's

1. Do verify that the flange size and type on the tank match the sight glass specifications before installation.
2. Do clean the flange surface thoroughly before placing the gasket to ensure a proper seal.
3. Do use a new gasket for every installation to prevent leaks and ensure a reliable seal.
4. Do use a torque wrench to tighten the bolts evenly in a criss-cross pattern to avoid uneven pressure and gasket deformation.
5. Do gradually pressurize the tank after installation to check for leaks and ensure the sight glass is properly sealed.
6. Do wear appropriate PPE (gloves, safety glasses, face shield) during installation to ensure personal safety.
7. Do inspect the sight glass periodically during regular maintenance to ensure it remains in good condition.
8. Do follow the manufacturer's torque specifications for tightening bolts to prevent overtightening or undertightening.
9. Do monitor the sight glass during the initial hours of operation after installation to ensure it functions correctly.

Don'ts:

1. Don't reuse old gaskets; always install a new gasket to maintain a proper seal.
2. Don't overtighten the bolts as this can damage the gasket and the sight glass, leading to leaks.
3. Don't use damaged or corroded bolts; replace them with new, corrosion-resistant bolts if necessary.
4. Don't skip the cleaning of the flange surface, as debris or old gasket material can prevent a proper seal.
5. Don't use a makeshift tool or guesswork for tightening bolts; always use a torque wrench to ensure even pressure.
6. Don't operate the tank without performing a pressure test after installation to check for leaks.
7. Don't ignore signs of wear or damage on the sight glass or gasket during routine inspections; replace them promptly.
8. Don't attempt to install the sight glass on a pressurized or filled tank; always ensure the tank is depressurized and empty.
9. Don't neglect regular maintenance; routine checks are essential for ensuring long-term reliability and safety.

Satisfaction Guarantee

