

WELD TO TANK
SIGHT GLASS ZW30
LED LIGHTING

Douglass

See more, see better



WELD TO TANK

SIGHT GLASS ZW30 - LED LIGHTING

Overview:

The Douglass ZW30 LED - Weld-to-Tank Sight Glass is a robust and versatile solution designed for industrial applications that demand reliable visibility into tank processes. Engineered for tanks operating under 300 PSI, this sight glass combines ease of installation with a sleek, professional appearance. Its durable construction and compatibility with various materials make it ideal for a wide range of environments, from chemical processing to food and beverage production.

The ZW30 offers both standard and customizable options, ensuring it meets the specific needs of any project, while its aesthetically pleasing design enhances the overall look of the installation.

The addition of the LED system enables the user to illuminate vessels which are not naturally illuminated or don't have a natural access to light. LED can come in 12/24 V, with the option for 110/220 A. Under special requests, these lamps can be explosion-proof or have an IP rating.

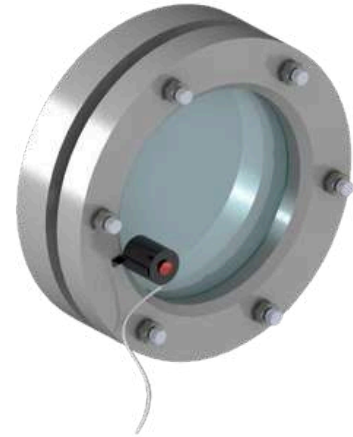

Advantages:

- **Ease of Installation:** The ZW30 is designed for quick and straightforward installation, reducing downtime and labor costs during setup. Its user-friendly design ensures that even complex installations can be completed efficiently.
- **Aesthetic Design:** The screws are positioned into the upper flange, giving the ZW30 a clean and professional appearance. This makes it an excellent choice for installations where visual appeal is important.
- **Customizable Options:** While the ZW30 comes in standard sizes, it offers customization options to meet specific project requirements, including adjustments to metal thickness, glass type, and gasket materials.
- **Cost-Effective Solution:** The ZW30 provides a reliable and durable sight glass solution at a competitive price, making it an excellent choice for industries looking to balance performance with cost-efficiency.
- **Durable Construction:** Built from high-quality materials like carbon steel or stainless steel, the ZW30 is resistant to corrosion and wear, ensuring long-term performance even in challenging environments.
- **Versatility:** Suitable for a wide range of industrial applications, from chemical processing to food and beverage production, the ZW30 can be adapted to various operating conditions and requirements.
- **LED Lighting:** For installations in dark environments, the ZW30 can be equipped with an optional LED light, enhancing visibility and safety. The light is protected by a polycarbonate layer to prevent damage from potential explosions inside the tank.

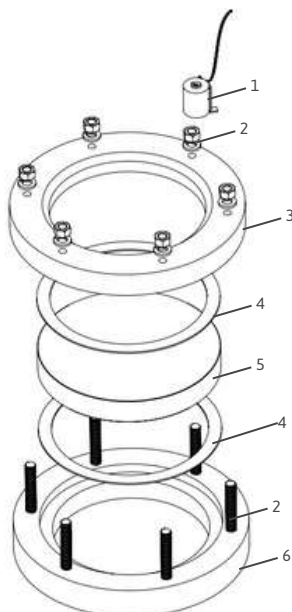

Parts and Materials:

Item	Part name	Material options
1	LED Vision	
2	Bolts	<ul style="list-style-type: none">· Stainless Steel 316L· Stainless Steel 304
3	Cover Flange	<ul style="list-style-type: none">· Stainless Steel 316L· Stainless Steel 304· Carbon Steel w/ anti-corrosion coating
4	Gasket (max temp)	<ul style="list-style-type: none">· Buna· Neoprene· Teflon· Sanitary Rubber· EPDM· Viton
5	Sight Glass	<ul style="list-style-type: none">· DIN7080 Tempered Borosilicate· DIN8902 Tempered Soda Lime· Polycarbonate· Quartz
6	Weld Pad	<ul style="list-style-type: none">· Stainless Steel 316L· Stainless Steel 304· Carbon Steel w/ anti-corrosion coating

WELD TO TANK

SIGHT GLASS ZW30 - LED LIGHTING

TECHNICAL INFORMATION

ID	A (Visible Diam)	B (Total Diam)	C (Total Thickness)
3"	3" (76.20 mm)	5" (127.00 mm)	1.5" (38.1 mm)
4"	4" (101.6 mm)	6" (152.40 mm)	1.5" (38.1 mm)
5"	5" (127.00 mm)	7.5" (190.50 mm)	2" (50.8mm)
6"	6" (152.40 mm)	9" (228.60 mm)	2" (50.8mm)
7"	7" (177.80 mm)	10" (254.00 mm)	2.5" (63.5 mm)
8"	8" (203.20 mm)	11" (279.40 mm)	2.5" (63.5 mm)
9"	9" (228.60 mm)	12" (304.80 mm)	3" (76.2 mm)

Installation Instructions for Weldable to Tank Sight Glass with LED Vision (Douglass Brand)

Tools and Materials Required:

- Welding machine
- Welding rods/electrodes (suitable for the materials)
- Torque wrench (calibrated)
- Gaskets (as specified, typically non-reusable)
- Bolts and nuts (as specified)
- Protective gear (welding mask, gloves, etc.)
- LED light kit

1. Preparation:

- Clean the tank surface, ensuring that the opening is free of debris, rust, or contaminants.
- Verify that all necessary components (sight glass, gaskets, bolts, nuts, etc.) are present and in good condition.

2. Position the Sight Glass:

- Place the weldable sight glass onto the tank opening, ensuring it aligns correctly with the tank neck.
- Confirm that the sight glass sits flush against the tank's surface and mark the positions for welding if needed.

3. Welding:

- Using an appropriate welding technique (TIG/MIG), weld the sight glass neck or flange to the tank, following the contours evenly.
- Ensure consistent attention to the entire circumference to prevent uneven stress or weak points.
- Achieve a continuous, full-penetration weld to guarantee a secure, leak-proof seal.
- Allow the welded area to cool naturally to avoid warping or introducing stress to the materials.

4. Install Glass and Gaskets:

- Position the first gasket on the flange of the sight glass, ensuring proper alignment along the entire opening.
- Carefully center the glass on the gasket.
- If required by the design, place a second gasket over the glass to ensure a proper seal.

5. Secure the Assembly:

- Align the upper flange with the sight glass neck or flange.
- Insert the bolts evenly into the provided holes around the sight glass.
- Gradually tighten the bolts in a criss-cross (star) pattern to ensure even compression of the gasket.
- Use a torque wrench to tighten the bolts to the specified torque, avoiding over-tightening, especially near the glass edges.

6. Final Checks:

- Inspect the welded joints for any gaps, cracks, or visible defects.
- Ensure the gasket is evenly compressed and that the sight glass is securely aligned, showing no signs of stress or misalignment.

7. Install LED Light:

- Follow the manufacturer's instructions to install the optional LED light kit.
- Ensure the light is securely connected and functioning properly.

8. Testing:

- Conduct a pressure test to check for leaks and confirm the sight glass is securely installed.

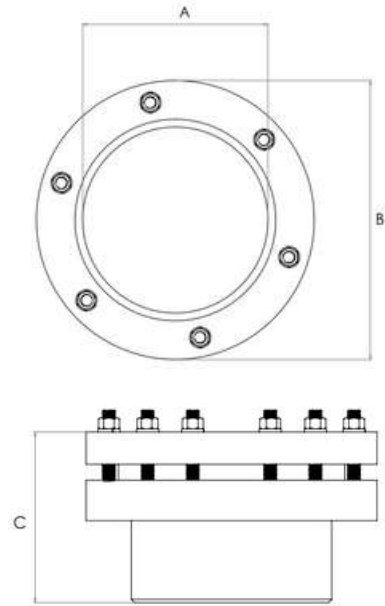

Do's:

1. Do inspect regularly: Conduct routine inspections to ensure the sight glass, gaskets, and welds are in good condition.
2. Do replace gaskets as needed: Always use new, undamaged gaskets when performing maintenance or if leaks are detected.
3. Do clean the glass: Keep the sight glass clean both inside and outside to maintain clear visibility.
4. Do follow torque specifications: Use a torque wrench to evenly tighten bolts to the specified torque value during installation and maintenance.
5. Do depressurize the tank: Always depressurize the tank before performing any maintenance or replacement on the sight glass.

Don'ts:

1. Don't reuse gaskets: Never reuse old gaskets; this can lead to leaks or improper sealing.
2. Don't overtighten bolts: Over-tightening can damage the glass or gaskets, leading to potential leaks or failure.
3. Don't ignore signs of damage: If you notice any cracks, chips, or other damage to the glass, replace it immediately to avoid safety hazards.
4. Don't use abrasive cleaners: Avoid using abrasive materials or harsh chemicals to clean the glass, as they can scratch or weaken it.
5. Don't skip regular maintenance: Failing to maintain the sight glass can lead to decreased performance, leaks, and potential safety issues.

How to order:

To make the ordering and specification of your ZW30 easier, please ask your sales representative for a model by filling out the following chart:

Keep in mind these are for standard items, any custom-made application can be tackled directly with your sales representative.

